

# Stationary concrete pump

# BSA 1005 D5 (F80)

Output up to 52 m<sup>3</sup>/h  
Delivery pressure up to 70 bar

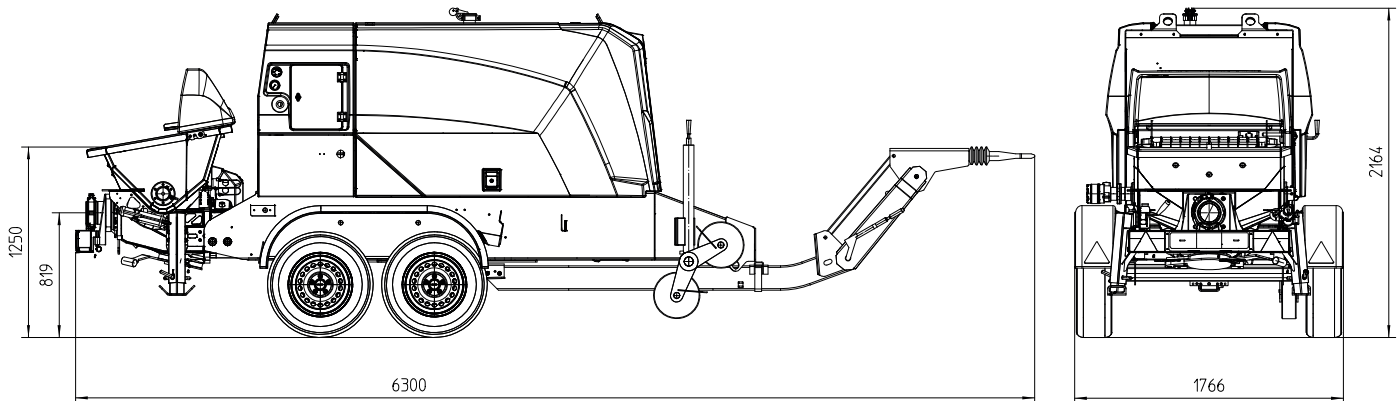

Note: Standard. Dimensions and weights depend on equipment. Subject to technical modifications and errors.

## Technical data

Model		BSA 1005 D5 (F80)
Material number		102682.000
Output	m <sup>3</sup> /h	52
Delivery pressure	bar	70
Delivery cylinder	Ø mm	180
Delivery cyl. stroke	mm	1000
Strokes / minute		33
Engine / motor power	kW	55.4
Hopper		RS 488
Capacity	l	approx. 300
Filling height	m	1.25
Transfer tube		S 1812
Line connection	mm	SK 125
Pressure connection	"	5.5
Control system		Ergonic 3 PS
Diesel tank	l	120
Weight	kg	3100

## Serial equipment

Agitator safety switch off	Operating manuals (1× paper, 1× CD-ROM) spare part list
Cable remote control 10 m	Output adjustment, electrical
Central lubrication on hopper with grease gun	Outriggers 3× mech.
Chassis F80	Speed drawdown automatically on pump stop (Diesel driven only)
Cleaning accessories	Splash guard
Coloring: Pump, frame, roof anthracite-grey Doors chrome yellow	Support wheel
Concrete hopper with agitator	Tool set incl. standard equipment
Drawbar eye (DIN)	
Drive diesel, Deutz 55.4 kW, Stage 5 (1005 D5)	
Electronic error management	
Ergonic Graphic Display	
Flushing water pump 50 l/min 20 bar	
Grill 60 mm	

All data maximum theoretical

See quotation for exact serial delivery scope.  
Comprehensive range of options available on request.